

INTRODUCTION

These instructions provide installation procedures for the HP 12903B Slide Mounting Kit. This slide mounting kit is for mounting certain instruments in Hewlett-Packard 19-inch equipment rack cabinets; e.g., HP 2860B/C/D/E or HP 29400A/B Series Cabinets.

KIT CONTENTS

The HP 12903B Slide Mounting Kit consists of the following:

DESCRIPTION	HP PART NO.	QUANTITY
Nut, spring channel, no. 8-32	0590-0818	8
Slide Assembly	1494-0012	1 pair
Washer, lock, split, helical, no. 10	2190-0034	12
Washer, lock, split, helical, no. 8	2190-0073	4
Screw, machine, flathead, no. 6-32, 3/4 in.	2360-0204	8
Screw, machine, flathead, no. 8-32, 3/8 in.	2510-0102	4
Screw, machine, panhead, no. 8-32, 3/8 in.	2510-0103	4
Screw, machine, flathead, no. 10-32, 3/8 in.	2680-0100	12
Nut, plain, hexagon, no. 10-32	2740-0002	12
Washer, flat, no. 8	3050-0139	4
Slide Bracket, right	12903-00002	1
Slide Bracket, left	12903-00003	1

INSTALLATION

Install the HP 12903B Slide Mounting Kit as follows (see figure 1):

- a. Place the instrument on a table.
- b. Remove the chassis member from each slide assembly and attach it to each slide bracket with six 10-32 x 3/8 inch flathead screws, lockwashers, and nuts.

Note: Do not remove intermediate member from stationary member.

- c. Pivot each chassis member to access the slide bracket mounting holes and attach one slide bracket to each side of the instrument with four 6-32 x 3/4 inch flathead screws.
- d. Install two spring channel nuts in each of the four rack columns at the approximate mounting level.
- e. Attach rear of each stationary member to rack cabinet with two 8-32 x 3/8 inch panhead screws, flat washers, and lockwashers in alignment with the two spring channel nuts. Attach front of each stationary member to rack cabinet with two 8-32 x 3/8 inch flathead screws in alignment with the two spring channel nuts. Ensure that each stationary member is level from front to rear.
- f. In the stationary members, extend the intermediate members out from the front of the rack cabinet.
- g. Lift the instrument to the cabinet mounting area and mate the chassis members with the extended intermediate members in front of the rack cabinet.
- h. Push the instrument into the rack cabinet until it stops at a detent position.
- i. Press in on the slide lock buttons located on the sides of the chassis members and push the instrument into the rack cabinet until it is seated fully.
- j. To prevent the instrument from accidentally sliding out, it is recommended that the instrument be secured to the front of the rack cabinet.

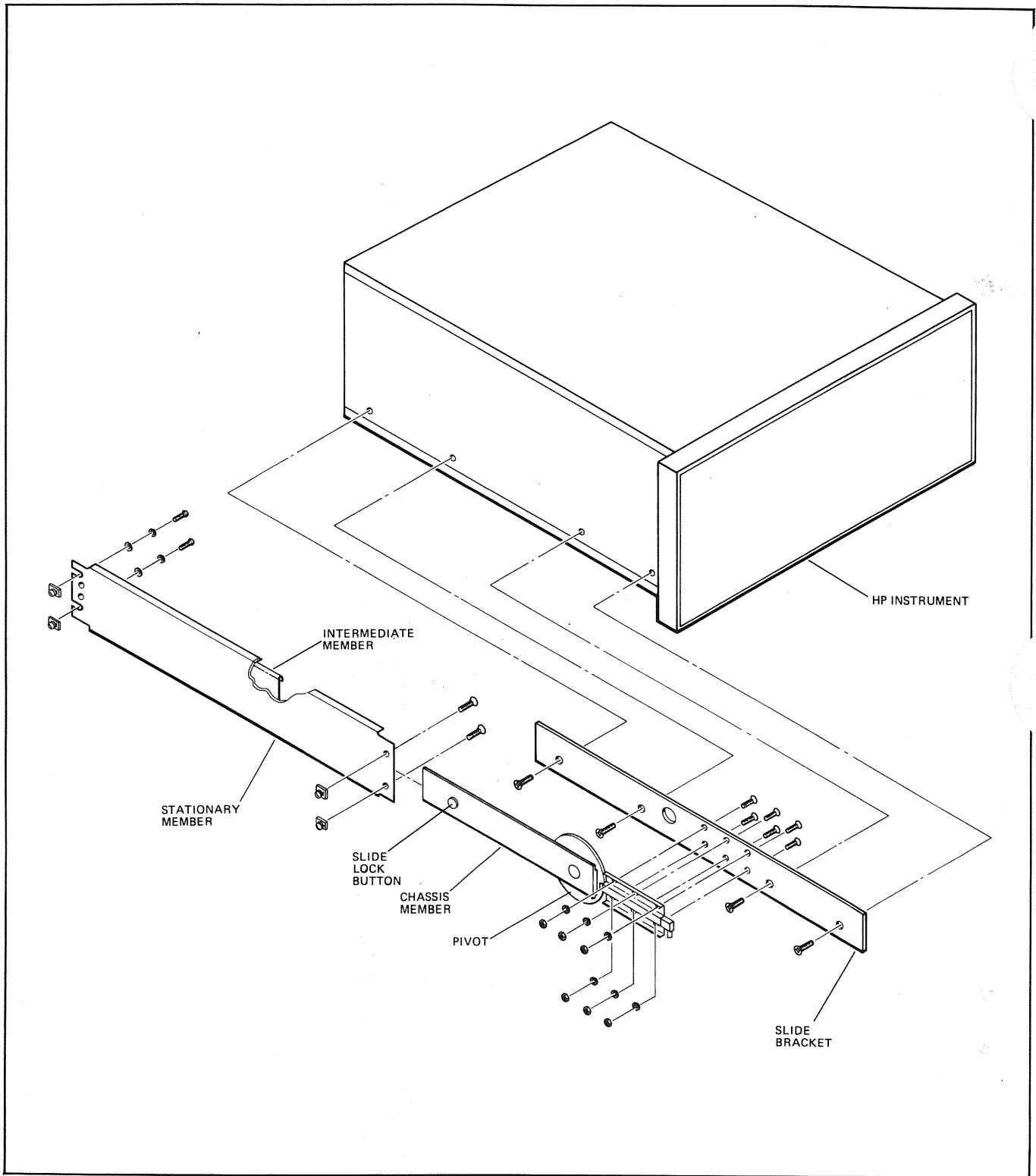

7080-11

Figure 1. Installation Details